

Triple-level and Sensor Terminal Blocks

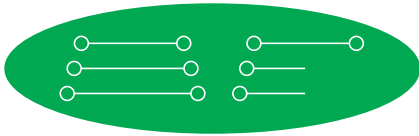

Our triple-level terminal blocks enable either high-density wiring or simplified, low-cost sensor wiring. When wiring space is at a premium, use the DN-TL14 to connect three separate circuits in only 5 mm of linear DIN rail space. The rest of our family of triple-level blocks will allow you to wire one terminal block per sensor, vs. the traditional method, which requires three different single-level blocks per sensor. The DN-TL14S is our standard sensor terminal block, and the DN-TL14SLP and DN-TL14SLN provide LED indication at the terminal block when voltage is present.

14 AWG

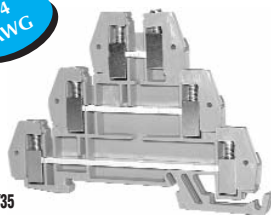

DN-TL14
Series: EURO W 2.5/35

SENSOR

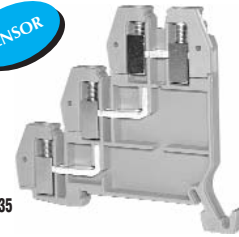

DN-TL14S
Series: EURO Z 2.5/35

	Part #	Pcs/Pkg	Price/Pkg	Part #	Pcs/Pkg	Price/Pkg
Gray Term Block	DN-TL14	25	<--->	DN-TL14S	25	<--->
Triple-level and Sensor Terminal Blocks Specifications						
UL Approval*	300V	10A	26-14AWG	300V	10A	26-14AWG
CSA Approval	300V	10A	26-14AWG	300V	10A	26-14AWG
VDE Approval	300V	10A	2.5mm ²	300V	10A	2.5mm ²
CE Conformity	CE 23/20, CE 23/21			CE 23/20, CE 23/21		
Agency File #	E179129			E179129		
Wire Strip Length	0.39" (10mm)			0.39" (10mm)		
Tightening Torque	4.5 lb-in. (0.50 Nm)			4.5 lb-in. (0.50 Nm)		
Density	57 pcs./ft. (200/m)			57 pcs./ft. (200/m)		
Operating Temperature	Ambient air temperature: -13°F to 104°F (-25°C to 40°C) Relative humidity: 50% max at 104°F (40°C); 90% max at 68°F (20°C)					
<i>* Note: For copper wire only</i>						

Accessories						
	Part #	Pcs/Pkg	Price/Pkg	Part #	Pcs/Pkg	Price/Pkg
35 mm DIN Rail	ADC Part No. DN-R35S1 (7.5 mm) or DN-R35HS1 (15 mm)				10	various
End Bracket	DN-EB35				50	<--->
	DN-EB35MN				20	<--->
	DN-EB35-A				50	<--->
	DN-QEB35				50	<--->
End Cover	DN-EC14	25	<--->	DN-EC14S	25	<--->
Jumpers / 2 Pole Blue	DN-2JL14B				100	<--->
/ 3 Pole Blue	DN-3JL14B				100	<--->
/ 4 Pole Blue	DN-4JL14B				100	<--->
/ 12 Pole Blue	DN-12JL14B				10	<--->
/ 2 Pole Red	DN-2JL14				100	<--->
/ 3 Pole Red	DN-3JL14				100	<--->
/ 4 Pole Red	DN-4JL14				100	<--->
/ 12 Pole Red	DN-12JL14				10	<--->
Marking Tags	DN-LAT series				500	<--->
Angled Support Bracket	DN-ASB1				50	<--->

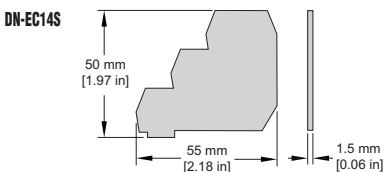
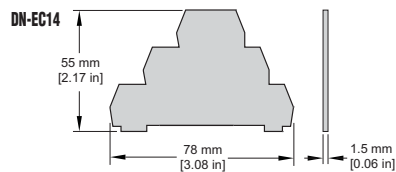
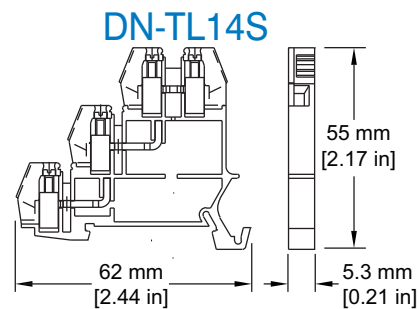
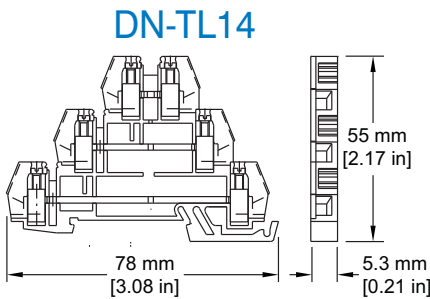

Sensor wiring has never been this simple.

- A** Wire the bottom two levels of one DN-TL14 to connect your power supply to what will become a sensor +V and -V power bus.
- B** Mount the triple-level sensor blocks next to the DN-TL14. (The DN-TL14S is our standard sensor terminal block. The DN-TL14SLP gives you LED indication for PNP sensors, and the DN-TL14SLN gives you LED indication for NPN sensors.)
- C** Use the top level to connect the first sensor signal line to the PLC.
- D** Connect the power supply terminals of the DN-TL14 to the LED sensor terminal blocks by installing jumpers. This will create a +V and -V power bus on the two bottom levels of the terminals. Use an external wire to connect a group of 12 DN-TL14s to another group.
- E** Wire the sensor signal lines through the top levels of the blocks to your PLC or controller. Remember to use the appropriate end covers to cover any exposed metal parts for safety purposes.

For more information on accessories, see the "DINnectors Accessories" section of this chapter.

See example wiring diagram on next page

Sensor Terminal Blocks with LED

LED
PNP

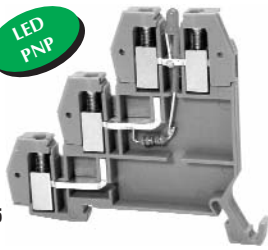

DN-TL14SLP
Series: EURO 2 2.5 LP/35

LED
NPN



DN-TL14SLN
Series: EURO 2 2.5 LN/35

Gray Term Block	Part #	Pcs/Pkg	Price/Pkg	Part #	Pcs/Pkg	Price/Pkg
	DN-TL14SLP	25	<--->	DN-TL14SLN	25	<--->
Sensor Terminal Blocks with LEDs Specifications						
UL Approval*	300V	10A	26-14AWG	300V	10A	26-14AWG
CSA Approval	300V	10A	26-14AWG	300V	10A	26-14AWG
VDE Approval	300V	10A	2.5mm ²	300V	10A	2.5mm ²
CE Conformity	CE 23/20, CE 23/21			CE 23/20, CE 23/21		
LED Voltage	12 - 24V AC/DC. 3.4 kΩ			24V AC/DC		
Agency File #	E179129			E179129		
Leakage Current	25mA@5V			25mA@5V		
Wire Strip Length	0.39" (10mm)			0.39" (10mm)		
Tightening Torque	4.5/lb.-in. (0.50 Nm)			4.5/lb.-in. (0.50 Nm)		
Density	57 pcs./ft. (200/m)			57 pcs./ft. (200/m)		
Operating Temperature	Ambient air temperature: -13°F to 104°F (-25°C to 40°C) Relative humidity: 50% max at 104°F (40°C); 90% max at 68°F (20°C)					
*NOTE: For copper wire only						

Accessories							
	Part #	Pcs/Pkg	Price/Pkg	Part #	Pcs/Pkg	Price/Pkg	
35 mm DIN Rail	ADC Part No. DN-R35S1 (7.5 mm) or DN-R35HS1 (15 mm)			10 various			
End Bracket	DN-EB35			50 <--->			
	DN-EB35MN			20 <--->			
	DN-EB35-A			50 <--->			
	DN-QEB35			50 <--->			
End Cover	DN-EC14S			25 <--->			
Jumpers	/ 2 Pole Blue	DN-2JL14B			100 <--->		
	/ 3 Pole Blue	DN-3JL14B			100 <--->		
	/ 4 Pole Blue	DN-4JL14B			100 <--->		
	/ 12 Pole Blue	DN-12JL14B			10 <--->		
	/ 2 Pole Red	DN-2JL14			100 <--->		
	/ 3 Pole Red	DN-3JL14			100 <--->		
/ 4 Pole Red	DN-4JL14			100 <--->			
/ 12 Pole Red	DN-12JL14			10 <--->			
Marking Tags	DN-LAT series			500 <--->			
Angled Support Bracket	DN-ASB1			50 <--->			

DN-TL14SLP

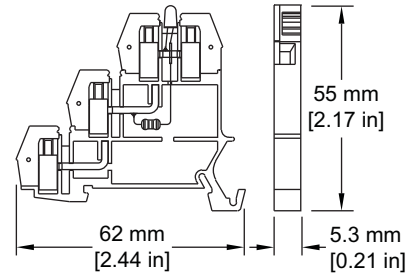

DN-TL14SLN

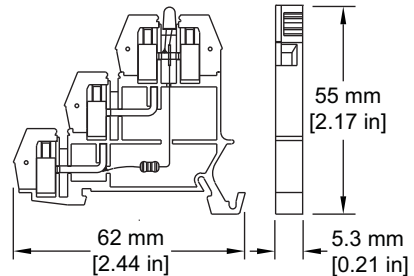

Screwless, plug-in, insulated jumpering system

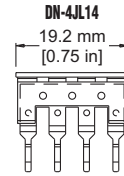
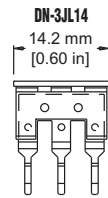
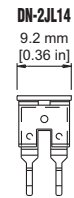

DN-12JL14

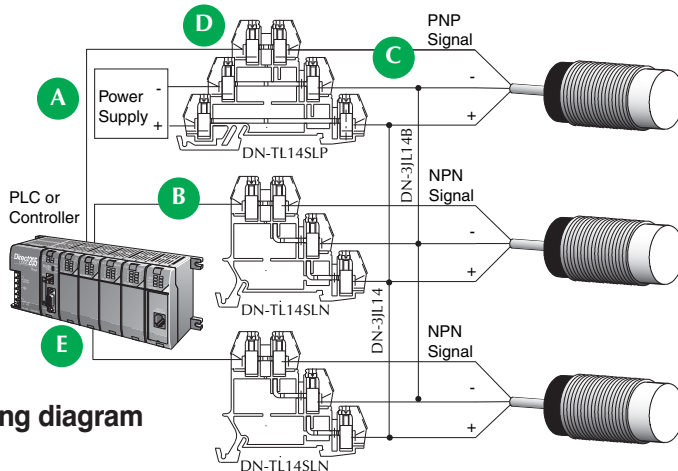
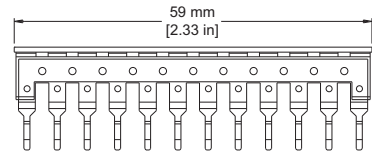

Sensor wiring diagram

For more information on accessories, see the "DINnectors Accessories" section of this chapter.