

Fiber Optic Ethernet Link

For Internal Installation in PC's

10Base-T to 10Base-FL

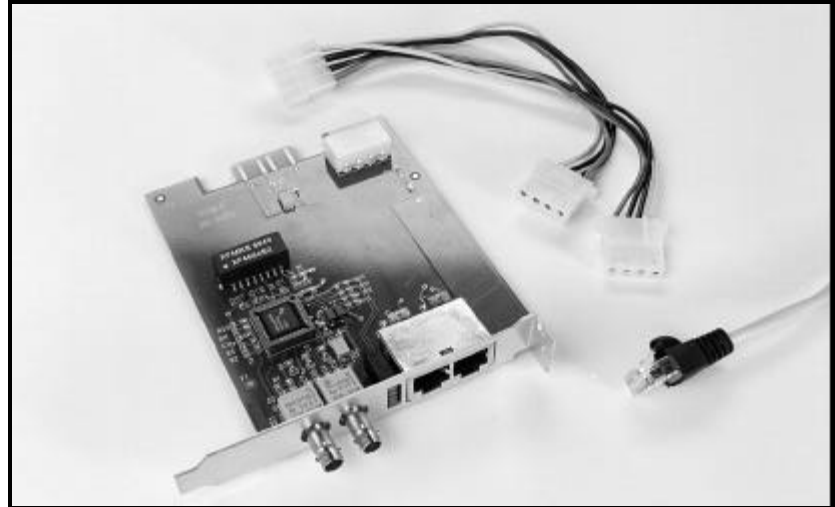

RELIABILITY

- Operates 0° C to +70° C
- Designed for 20 year life
- Device to device electrical isolation
- EMI and RFI immune
- IEEE 802.3 compatible
- 2 x RJ-45 connectors –
 - Eliminates crossover switches for higher reliability

SIGNAL INTEGRITY

- Automatic polarity detection and correction
- Supports EIA / TIA 568 UTP, cat. 3, 4, 5
- Auto adapts to 10Mbps half-duplex or 20Mbps full-duplex
- Supports multi-mode or single-mode fiber
 - 2 km – 850 nm M-M
 - 5 km – 1300 nm M-M
 - 14 km – 1310 nm S-M
- Capable of driving 100meters of UTP cable

COST EFFECTIVE

- Upgrade any PC to fiber ready with this internal converter card
- Completely software independent and transparent
- Powers from PC's 5 Vdc power supply
 - less than 2 watts

QUICK, FLEXIBLE, EASY INSTALLATION

- Five status / diagnostic LEDs:
 - Power, TP Idle, TP Data, FO Idle, FO Data
- CE compliant
- Mounts in minutes in any ISA or PCI slot
- 300mm, (1ft), shielded jumper cable RJ-45 to RJ-45 provided
- PC power cable included

SIMPLE, ECONOMICAL AND EASY TO USE

Dymec Links, Models 2310, 2312, and 2314 are simple media converters that convert 10Base-T Ethernet from twisted pair copper to 10Base-FL fiber optics. These Links simply plug into a spare ISA or PCI computer slot. They require no programming or set up. The only PC resource that they use is 5 volts dc.

During installation, one plugs in the Link next to an Ethernet Network Interface Card (NIC) that operates 10Base-T. Connect the power cord (included) to the PC's 5 Volt Bus and the 300mm (12 inch) jumper cable (also included) to the NIC port. Once the Computer is re-energized, a Red LED illuminates on the Link board verifying that the Link is powered correctly. When the fiber is connected to another operating IED, the external LEDs (TP Idle and FO Idle) tell you that the Link is operating. LEDs TP Data and FO data verify that data is passing.

Each Link has two RJ-45 ports, one is connected for a "straight-thru" configuration, the other for a "cross-over" configuration.

FIBER OPTICS OFFERS UNIQUE BENEFITS

The Model 2310 utilizes 850 nm optics for multi-mode cable and can connect to another IED up to 2 km (6,560ft.) away. The Model 2312 uses 1300 nm optics for multi-mode cable and can span a distance of up to 5 km (16,400 ft.). The Model 2314 uses 1310 nm single-mode optics, which are rated -10° to +50° C, and can extend the line up to 14 km (8.7 miles). These distances are for point to point applications only. When used in a LAN configuration, actual distances may be limited due to Ethernet timing rules of 51.2 micro-seconds round trip time.

In addition to extending the distance that a signal can be transmitted, the use of Fiber Optics provides greater immunity to environmental "noise" that can corrupt the signal. These "noise" generators can be in the form of EMI, RFI or GPR. Since Fiber is non-conductive, it is impervious to these signal contaminants.

Models 2310, 2312, and 2314

Specifications

Electrical

UTP Interface RJ45
LAN Protocol (UTP) 10Base-T

Optical

	850	1300	1310(SM)
Optical Interface	ST	ST	ST
Optical Output (dBm)	-19	-17.5	-27.4
Receiver Sensitivity (dBm)	-32.5	-28.9	-36
Optical Budget (dB)	13.5	11.4	8.6

Compatible FOC

Model 2300	50, 62.5, 100, & 200 μ m
Model 2312	50, & 62.5 μ m
Model 2314	5 to 13 μ m

Timing

Start-up delay 575 nano-sec Max.
(5 bit times)
Steady state Delay 110 nano-sec Max.

Power Requirements

Model 2300	5 Vdc	210 ma – 1.05 W
Model 2312 & Model 2314	5 Vdc	250 ma – 1.25 W

Applications

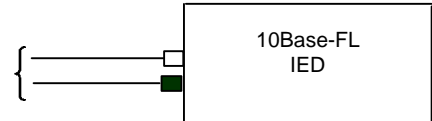
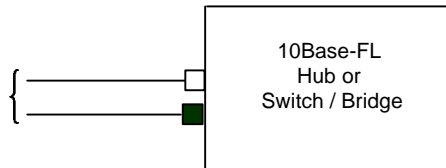
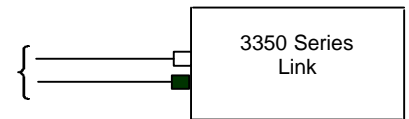
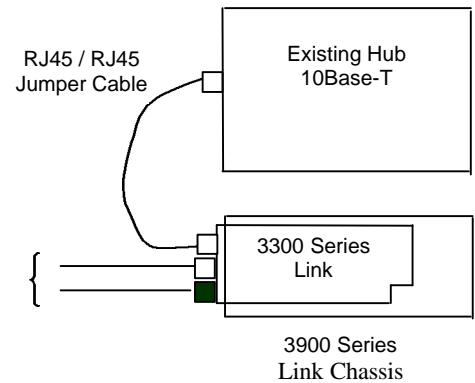
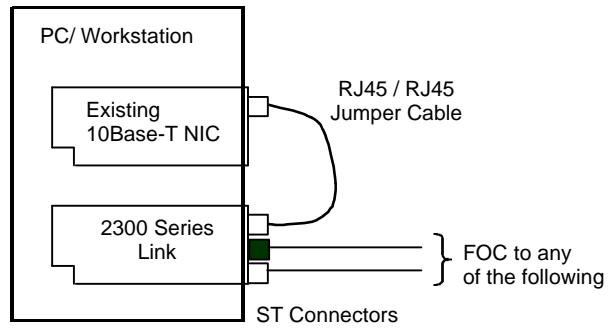

Ordering Information

Model	Optical Wave Length / Type Of FOC	Connectors - Electrical / Optical	Max. Point - To - Point Range *
2310	850 nano meter / Multi-Mode	RJ-45 / ST	2 km / 6,650 ft. (-40° to 85° C)
2312	1300 nano meter / Multi-Mode	RJ-45 / ST	5 km / 16,400 ft. (-40° to 85° C)
2314	1310 nano meter / Single-Mode	RJ-45 / ST	14 km / 8.7 miles (-10° to 50° C)

Specifications are subject to change without prior notice

* These distances are for point to point installation only. In a LAN, Ethernet timing rules may dictate shorter operating distances